

AUTOMATION AND CONTROL OF ELECTRIC POWER GENERATION AND DISTRIBUTION SYSTEMS: STEAM TURBINES

Bennauer M., Egener E.-G., Schlehuber R., Werthes H. and Zimmer G.
Siemens AG, PG, Mülheim, Germany

Keywords: steam turbine, turbine controller, load dispatcher, frequency control, load control, pressure control, control valve, start-up, load rejection, strong net, weak net, enthalpy, turbine characteristic, droop, bypass, base load, peak load, energy flow, fossil-fuelled

Contents

1. Introduction
 2. Functional Specifications
 - 2.1. Fundamentals of a Steam Turbine
 - 2.1.1. Sectioning and Reheating
 - 2.1.2. Steam Bypass
 - 2.1.3. Combined Heat and Power Generation
 - 2.2. Conversion from Mechanical Power into Electrical Power (Generator)
 - 2.3. Connecting Units
 - 2.3.1. Steam Generator
 - 2.3.2. Consumer Net
 - 2.4. Operating Conditions and Load Dispatching
 - 2.4.1. Base-Load Plant
 - 2.4.2. Peak-Load Plant
 3. Turbine Controller Design
 - 3.1. Steam Turbine Controller (Turbine Governor)
 - 3.1.1. Operating Modes
 - 3.1.2. Transition between Different Operation Modes
 - 3.1.3. Set-Up of the Turbine Controller
 - 3.2. Bypass Controller
 - 3.2. Bypass Controller
 4. Future Developments
- Acknowledgments
Glossary
Bibliography and Suggestions for further study
Biographical Sketches

Summary

This article outlines some basic principles and problems involved in generating electrical energy by means of steam turbines as prime movers. The main control issues for operating steam turbines, such as pressure control, speed control, load control, load shifts, and load rejections, are discussed.

1. Introduction

A steam turbine is a module to convert heat energy into mechanical energy. Thus it is one link in the chain of energy conversions with the aim of generating electrical energy. The first known energy conversions date back to the Stone Age when humans learned to transform mechanical or chemically stored energy into heat. The reversed process, turning heat into mechanical or electrical energy, however, was proven possible only in 1698 with Thomas Newcomen's development of a piston steam engine. A disadvantage of the Newcomen engine lay in the fact that heating and cooling took place in the same cylinder with each stroke. Thus only a few strokes per minute were possible. Commercial use of the steam engine became feasible after 1764 when James Watt improved the Newcomen engine by adding a separate condenser. Additionally, Watt developed an engine that rotated a shaft instead of providing the up-and-down motion of a pump. Further refinement of the original reciprocating engine led to a steam turbine, which may be regarded as the central part of a fossil-fuelled power plant.

Steam turbines were used as prime movers for electrical generators after the invention of the self-excited generator in 1869 by v. Siemens along with improvements by Edison and Upton that made it suitable for industrial use. The world's first permanent, commercial central power system came into operation in lower Manhattan in September, 1882.

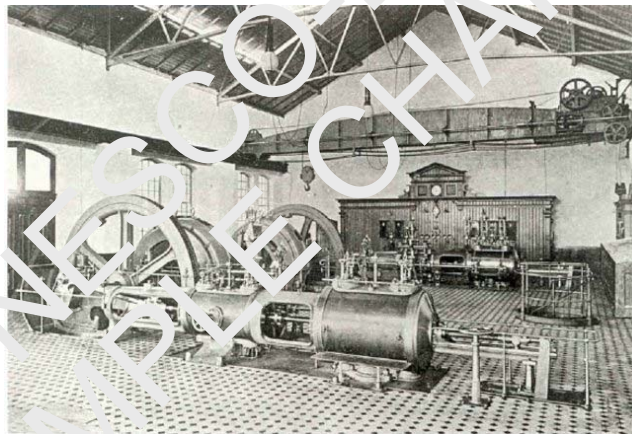

Figure 1. Power plant in 1891

In order to produce electrical energy, a series of energy conversions are conducted in fossil-fuelled power plants. Firstly, chemical energy stored in the form of fuel and oxygen is, by the process of combustion, transformed into thermal energy. In a second step, the heat energy is used to produce superheated steam. Steam turbines are designed to transform as much potential energy stored in steam as possible into mechanical energy. Finally, a generator transforms mechanical energy into electrical energy, which is available as electric current. Unfortunately, the energy conversion at every stage as described above is imperfect. In addition to the intended conversions, energy transfers to exhaust gas, waste heat, and mechanical losses have to be considered. The scheme of energy conversion as well as the energy flows are illustrated in Figure 2. Figure 3 schematically depicts a steam turbine embedded in a coal-fired power plant.

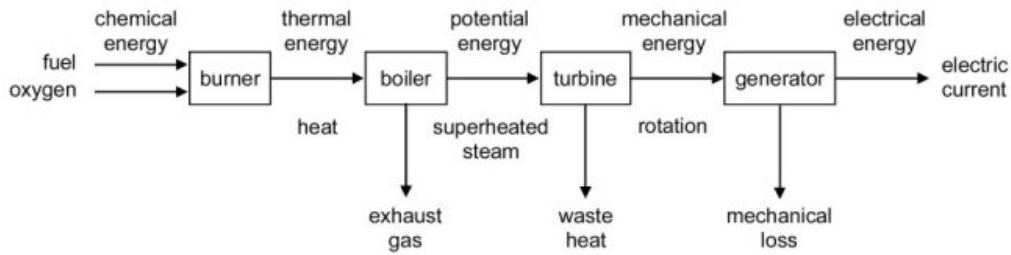

Figure 2. Energy conversion in a fossil-fuelled power plant

The energy that can be extracted from the steam is conveniently expressed in terms of the enthalpy drop across the turbine. The realizable enthalpy drop across a turbine increases with increased temperature and pressure of the steam delivered by the steam generator, and reduced turbine exit pressure.

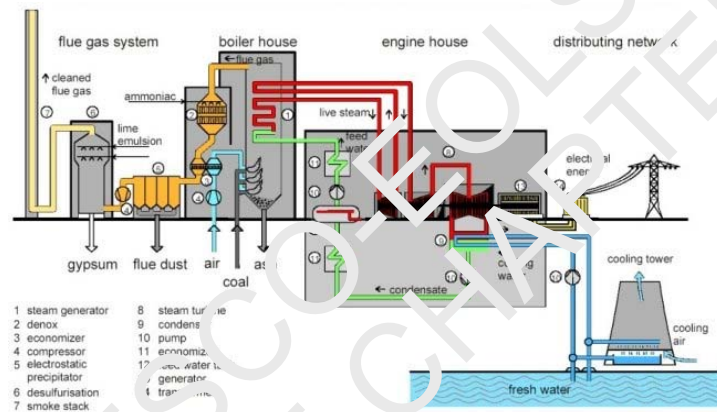

Figure 3. Components of a fossil-fuelled steam power plant; schematic overview

Since the early days, steam turbine development has undergone rapid progress. Until the early 1960s, the maximum rate of a steam turbine was around 150 MW, featuring an initial steam temperature of around 525 °C (977 °F) and a pressure of 125 bar (1813 pd inch⁻²). The end of the 1960s saw a rapid increase in steam turbine rate, which reached its temporary peak in the mid-1970s when steam turbines ratings of up to 800 MW became feasible.

Possible steam temperature increased only a little, to around 535 °C, but steam pressure rose up 245 bar (e.g. Maasbracht power plant, Maastricht, 1974, 535 °C, 245 bar, 630 MW). Today, fossil-fuelled steam power plants reach a rating of up to 1100 MW, with live steam temperature up to 580 °C and live steam pressure up to 265 bar (e.g. Frimmersdorf power plant, RWE Essen, 1995, 1025 MW, 575 °C, 265 bar).

In modern power plants, a —that is the ratio between the produced and the originally invested energy—of up to 46% can be achieved. Even better efficiency is obtained when a steam turbine is used in a combined cycle process. This means that a gas turbine and a steam turbine are combined into a single unit. In this case, the gas turbine's waste heat is recovered to produce the steam required by the steam turbine. Here efficiency of up to 60% is feasible.

Steam power plants are designed within a large rating range. The design point starts at 50 MW in a combined cycle plant, or at 100 MW in a stand-alone steam power plant, and goes up to approximately 1100 MW. For example, the lignite-fired power plant “Frimmersdorf,” where the turbo set was manufactured by Siemens KWU, is designed for a rating of 1030 MW; the lignite-fired power plant “Schwarze Pumpe” has two separate blocks, each designed for a rating of 874 MW.



Figure 4. Lignite-fired power plant “Schwarze Pumpe,” built in 1997

In contrast to hydroelectric power plants, which can be sited only where the environment suits their requirements, fossil-fueled power plants have the advantage that they can be built almost anywhere. Unlike water—the driving force of hydroelectric power plants—coal and other fossil fuels can be transported to the site where they are required.

Unlike fuel and oxygen, electricity—the final product in the conversion process—cannot be stored. To add to this problem, the supplier has almost no influence on the load at any time. Therefore, delivery has to be “just-in-time,” which requires feedback control at every stage of the energy conversion.

2. Functional Specifications

The central part of a steam turbine is a rotor that is turned by steam impinging against attached blades. The steam exerts a force on the blades in a tangential direction. Considering the steam as the driving force and a load as a resisting force, the rotor gains velocity as long as the driving force exceeds the resisting force. As soon as both forces match, the velocity remains constant. Since a turbine in a power plant drives an electric generator, it must run at constant speed.

The turbine governor controls all major parts of the plant associated with start-up, loading, changes in operating conditions such as speed or load acceptance, and shut-down of the turbine. The main task of the turbine governor is to match power production with demand at all times during operation and thus keep the velocity constant. Obviously, therefore, the design of the governor has to take the interconnections between neighboring units into account. To give a better understanding, the basics of the units involved are outlined below.

2.1. Fundamentals of a Steam Turbine

The basic task of a steam turbine is to convert steam power or enthalpy into mechanical power. Let p denote the steam pressure and T its temperature. Then the couple (p, T) defines the thermodynamic state of the steam. The absolute power P_s contained in steam is the product of the mass flow \dot{m} and the internal enthalpy h , which is a function of the state of the steam, $h = h(p, T)$, thus

$$P_s = \dot{m} h = \dot{m} h(p, T).$$

After being produced in the steam generator, the steam is continuously expanded inside the turbine until it finally reaches condenser pressure and temperature and therewith condenser enthalpy. The steam mass flow \dot{m} through the turbine can be influenced through a control valve in front of the turbine. The lift h_V of the control valve and the pressure before and after the valve determines the mass flow through the valve itself and finally the mass flow through the turbine.

Thus the steam flow from steam generator to condenser is basically, as depicted in Figure 5.

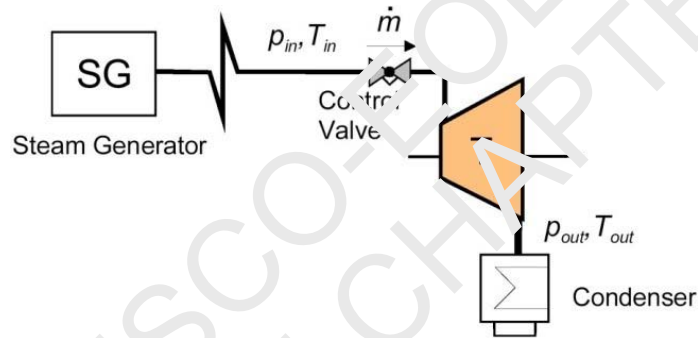

Figure 5. Steam flow through a turbine

Operational details of steam generators and condensers are explained below.

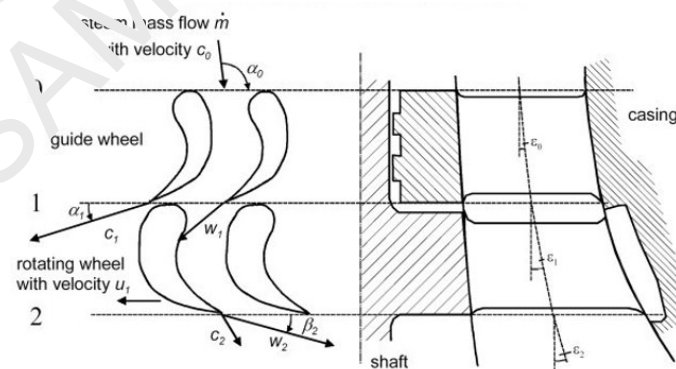

Figure 6. Guide wheel and rotating wheel. c_i : absolute velocities; w_i : velocities relative to the rotating wheel

Power transfer from steam to the rotating shaft of the turbine is carried out by leading

the steam alternately through a guide wheel, which is fixed to the casing and determines the direction of the steam flow, and a rotating wheel, which is fixed to the shaft. In this process the internal steam enthalpy decreases and the turbine gains torque and/or velocity. A section containing a guide wheel and a rotating wheel, as depicted in Figure 6, is called a stage of the turbine.

The mechanical power, P_{mech} , produced by this process is the product of the turbine torque M_T and the turbine angular velocity ω , $P_{mech} = M_T \omega$. Power transfer from steam to rotation takes place according to the equation

$$P_{mech} = \omega M_T = \eta \dot{m} \Delta h \quad (1)$$

Δh denotes the enthalpy difference between steam inlet and outlet and η the efficiency of the conversion.

In a control context, a steam turbine can be regarded as a system with the valve lift h_V as control input and the outgoing power P as the system output. In order to understand the different control issues involved in governing steam turbines, some more details of possible steam turbine operation modes need to be elucidated.

2.1.1. Sectioning and Reheating

In view of the great increase in volume during steam expansion, it is desirable to conduct the complete expansion process in a single turbine. Therefore, several stages are generally combined in a turbine section. Steam transition from one section to another gives the opportunity to spread the steam to two flows or to two (or more) identical sections. Generally, a turbine is sectioned into *HP* (high pressure), *IP* (intermediate pressure), and *LP* (low pressure) sections.

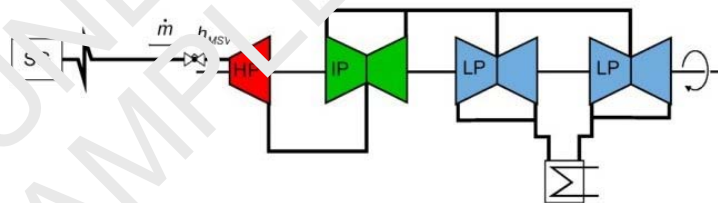

Figure 7 Turbine, divided into sections. First section: high pressure (HP); second section: intermediate pressure (IP), double flow; third section: low pressure (LP), tandem double flow.

In order to increase the efficiency of power generation, the steam may be reheated after being partly expanded in the first turbine section. To maintain pressure in the reheater, it is desirable to have another valve between the reheating section and the IP section. If the section in front of the IP section is large and thus able to store much thermal energy, this valve is essential to provide the possibility of quick energy blocking. The valve in front of the IP section is termed the reheat steam control valve or IP control valve. In order to tell the different control valves apart, the valve in front of the HP section is referred to as the main steam control valve.

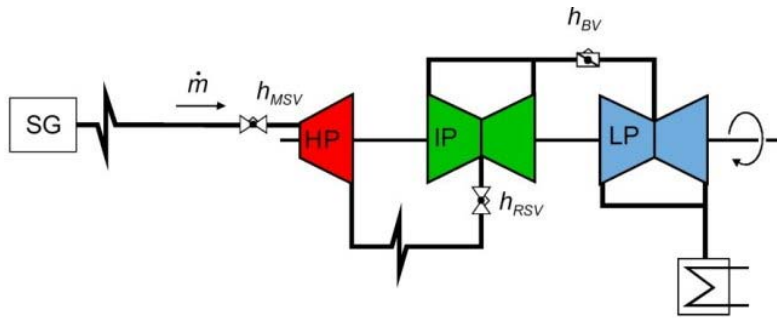

Figure 8. Reheating after the HP section

2.1.2. Steam Bypass

In some operating conditions, especially during start up or load rejection, more steam may be produced than can reasonably be consumed. This could cause the pressure in the steam generator and/or the piping and vessel system to exceed an allowable limit, and this pressure has to be relieved through safety valves. A bypass station is built to avoid loss of steam. Generally, there are two (possible) bypass stations: one bypasses the HP section and takes steam to the reheater, and the other bypasses the IP and LP section and leads into the condenser.

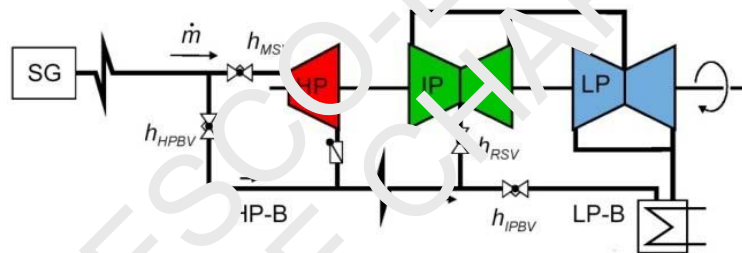

Figure 9. Turbine with HP and IP bypass station

Obviously each bypass section needs an additional control valve. These valves are termed the HP bypass control valve and the IP bypass control valve, respectively. In addition, a nonreturn valve after the HP section is required to prevent steam from entering the turbine at the wrong side.

2.1.3. Combined Heat and Power Generation

Some steam turbines are designed to also deliver process steam, for example for manufacturing needs or public heating. These turbine types possess additional steam outlets and are known as extraction turbines. In general, process steam is extracted from the IP or LP section.

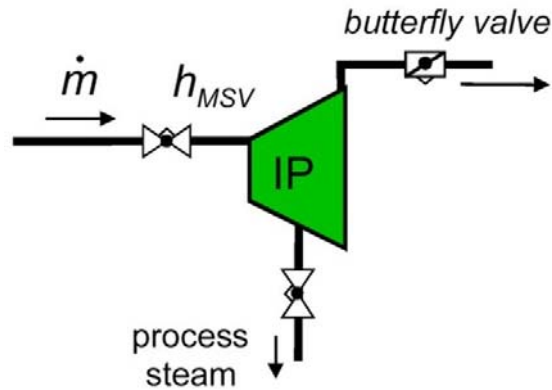

Figure 10. Process steam extraction, part drawing

Extraction turbines are further classified as bleeder turbines, where no effort is made to control the pressure of the extracted steam, and controlled extraction turbines, where the extraction steam pressure is kept constant.

In bleeder turbines, the pressure of the extracted steam varies according to the load imposed on the turbine. Controlled extraction turbines, in contrast, are designed to withdraw variable amounts of steam at constant pressure, irrespective of the turbine's actual load. Obviously; the option of extracting process steam at constant pressure requires an additional valve. A butterfly valve is commonly used to maintain pressure in front of the steam extraction pipe. This type of valve is suitable for large piping diameters and is cheaper than the commonly used control valves in front of the HP and IP-sections. On the other hand it cannot be controlled as precisely as the other control valves.

2.2. Conversion from Mechanical Power into Electrical Power (Generator)

The steam turbine and electrical generator are located on the same shaft. Therefore, although the conversion of mechanical power into electrical power is not an immediate function of the steam turbine, some basics of the generation of electrical current have to be considered and will be discussed briefly below.

-
-
-

TO ACCESS ALL THE 23 PAGES OF THIS CHAPTER,
Visit: <http://www.desware.net/DESWARE-SampleAllChapter.aspx>

Bibliography and Suggestions for further study

Böhm H. (1994). Fossilbefeuerte Kraftwerke. *VGB Kraftwerkstechnik* 74(3), pp. 173–186. [Overview on the state-of-the-art and development tendencies in fossil-fuelled power plants, in German.]

Fedderken W. and Kratzmeier A. (1993). Power plant operation and monitoring by remote control. *Siemens Power Journal*, 4, pp. 28–30. [A Practical example of power plant operation and monitoring by remote control is shown.]

Machowski J., Bialek J.W., Bumby J.R. (1997). *Power Systems Dynamics and Stability*. New York: John Wiley. [Exposition on the dynamics and stability of power systems.]

Ordys O.W., Pike A.W., Johnson M.A., Katebi R.M., and Grimble M.J. (1994). *Modelling and Simulation of Power Generation Plants*. London: Springer. [Overview of turbine process models.]

Pruschek R., Oeljekaus G., Haupt G., and Zimmermann G. (1997). *Kohlekraftwerke der Zukunft. BWK* 9–12, pp. 370–395. [Future perspectives of coal fired steam power plants.] [In German.]

Siemens AG, Energieerzeugung KWU (1995). *Turbogenerators*. Internal report. [The development of generator materials, insulation systems, cooling systems and design features are described.]

Sill U. and Zörner W. (1996). *Steam Turbine Generators, Process Control, and Diagnostics*. Publics MCD. Siemens sales literature. [Portrait of Siemens/KWU's state-of-the-art turbine and turbine generator series, displaying process engineering fundamentals and basic software concepts.]

UCPTE (1995). *Recommandations Relatives aux Reglages Primaire et Secondaire de la Frequence et de la Puissance dans l'UCPTE*. France: UCPTE. [Recommendations of an union for coordination of generation and transportation of electrical energy on primal and secondary frequency and a power control.] [In French.]

Wood A.J. and Wollenberg B.F. (1996). *Power Generation Operation and Control*. New York: John Wiley. [Exploration of engineering and economic matters involved in planning, operating, and controlling power generation and transmission systems.]

Biographical Sketches

Dipl.-Ing. Martin Bennauer is research engineer at Siemens PG, Steam Turbines and Electrical Generators in Mülheim an der Ruhr (Germany). After graduating as an electrical engineer he was research assistant at the control engineering laboratory of the Ruhr-University Bochum. His fields of interest include identification and simulation of steam turbine dynamics as well as application and further development of robust control methods.

Ernst-Günther Egener is the head of the department of instrumentation and control for steam turbines at Siemens PG Mülheim, Germany. After graduating at the Engineering Academy in Essen he joined the KWU AG (now Siemens PG) and was responsible for developing automation systems for steam turbines. As a manager of the Electrical Control Department he was responsible for the technical specification of electrical components and systems.

Rudolph Schlehuber is a mechanical engineer at Siemens PG, Mülheim Germany. His areas of responsibility are turbine control, and dynamic simulation related to control actions, as well as development of new controller concepts.

Heribert Werthes is a mechanical engineer at Siemens PG, Mülheim Germany. His areas of responsibility are turbine control and dynamic simulation related to control actions, as well as development of new controller concepts. He serves as a member in the VDI/VDE committees "Control of steam turbines," "Automation of conventional power plants," and "Control of synchronous machines/Gridcontrol."

Dr. Gerta Zimmer is a research engineer at Siemens PG, Mülheim, Germany, and Lecturer in Control Theory at the Technical University of Berlin (Germany). Her teaching responsibilities include robust and nonlinear control at graduate levels. Her research interests are in the field of nonlinear state observation, nonlinear descriptor systems, and steam turbine control. At Siemens PG she is responsible for the development of models and modules for the dynamical simulation of steam turbines, as well as for the development of new controller concepts and applicable methods.