

## **GAS TURBINE FUNDAMENTALS**

**H.I.H. Saravanamuttoo**

*Department of Mechanical and Aerospace Engineering, Carleton University, Canada*

**Keywords:** Gas turbines, cycles, performance, combined cycles

### **Contents**

1. Gas Turbines for Electric Power Generation
  2. Basics of Gas Turbine Operation
  3. Ideal Cycles
    - 3.1 Simple Gas Turbine Cycle
    - 3.2 Modifications to the Simple Cycle
      - 3.2.1 Heat Exchange Cycle
      - 3.2.2 Reheat Cycle
      - 3.2.3 Intercooling
      - 3.2.4 Heat Exchange, Reheat and Intercooling
  4. Real Cycles
    - 4.1 Typical Performance Results
  5. Combined Cycles
  6. Cogeneration Plant
  7. Off-design Performance
- Glossary  
Bibliography  
Biographical Sketch

### **Summary**

In recent years gas turbines have gained a significant portion of the power generation market, with the vast majority of units running on natural gas. Although many complex cycles are possible, nearly all gas turbines use the simple Brayton cycle. With continued developments in the fields of aerodynamics, metallurgy and manufacturing processes, pressure ratios of over 30 and maximum cycle temperatures of about 1600K can be achieved, yielding thermal efficiencies approaching 40 per cent.

For base load applications the combined cycle, using a Rankine cycle steam turbine with heat supplied from the gas turbine exhaust, is now widely used with thermal efficiencies above 55 per cent, with 60 per cent probably achievable in the early years of the 21st century.

In the event that world supplies of natural gas are severely depleted a future possibility is the gasification of coal in an integrated gasified combined cycle (IGCC); demonstration plants up to 400 MW began operation in the late 1990s. Gas turbines play a major role in off-shore power applications, where their compact size, low weight and high power density offer major advantages in the confined space available on an off-shore oil or gas platform.

## 1. Gas Turbines for Electric Power Generation : Introduction

The first successful application of the gas turbine for electricity generation was the 4 MW plant installed by Brown Boveri in Neuchatel, Switzerland, in 1938. There were no further developments during World War II and in the early post-war years there were some attempts to introduce gas turbines in this role, but these were basically unsuccessful for a variety of reasons; thermal efficiency was too low to be competitive with existing plant and the power available was too small to be significant in a large power generation system. When power outputs of 30 - 50 MW became available, a small number of installations began to appear but the efficiency was still totally inadequate for use as base load plant.

Interest in gas turbines for emergency duty arose following a major power system collapse in North America in the early 1960s. A primary failure in one key station led to overloading in other stations, resulting in a drop in frequency, which in turn led to shut down of auxiliaries such as boiler feed pumps, which then caused further plant shut downs and overloading; this resulted in a *cascade failure* with the whole system being shut down, leaving the entire Eastern seaboard without power for over 10 hours. Similar failures have also occurred in Europe and the Far East.

This led to a requirement for systems which could start automatically on sensing a falling frequency, and provide emergency power for the critical station auxiliaries such as boiler feed pumps. It was quickly realized that aircraft jet engines could be converted to drive a power turbine which could be coupled to a generator; because of the light weight construction of the aircraft engine these units could be easily started on their own battery power and brought up to maximum power in a very short time, typically 120 seconds. As a result, a large number of *aero-derivative* gas turbines, with powers of about 15 - 20 MW, were installed in both N. America and Europe for emergency duties; these units could also be used for peak loads.

At that time, the thermodynamic performance of the aircraft engines was greatly superior to that of the heavy duty industrial gas turbine, but the success of the *aero-derivatives* led to increasing interest in applying technology improvements to land based gas turbines; there was considerable technology transfer as well, and over the years the performance of the heavy industrial units has approached that of the *aero-derivatives*.

More importantly, however, the power available from the heavy frame turbines rose much more rapidly than that from the *aero-derivatives*; this was due to the movement towards high bypass turbofan engines, where the flow through the engine core remained relatively low even though the thrust increased dramatically. By the late 1990s the maximum power from *aero-derivatives* had reached about 50 MW, while the heavy industrials were capable of over 250 MW.

The availability of units of 100 MW and above allowed power stations to be built at substantial power levels with only a few units, and this initiated a large increase in the use of gas turbines. The efficiency, however, was still too low for base load applications apart from oil rich areas of the world where fuel cost was not critical. The key to obtaining high efficiency was the combination of the gas turbine (Brayton cycle)

with the steam turbine (Rankine cycle), with the high temperature exhaust from the gas turbine being utilized in waste heat boilers (or heat recovery steam generators) to raise steam for use in a steam turbine.

*Combined cycles* provided higher thermal efficiencies than were obtainable with any other systems for large power outputs, and this resulted in a large number of base load plants being built in the 1990s. In some countries these were based on natural gas and in others without local supplies of natural gas, on imported liquefied natural gas (LNG).

Gas turbines have also played an important role in electricity generation on off-shore oil and gas platforms. Large platforms may use in excess of 125 MW and there are severe limitations on weight and volume; for this reason, aero-derivatives are preferred for powers of 25 MW and above. There are, however, numerous smaller units in the 5 MW range where the industrial turbines are widely used.

Thus it can be seen that in a period of about 50 years following World War II the gas turbine has emerged as a significant participant in electrical power generation and, in combination with the steam turbine, has started to play a major role in base load power generation.

## 2. Basics of Gas Turbine Operation

The simplest arrangement of the gas turbine consists of a compressor, combustor and turbine directly connected to the generator as shown in Figure. 1.

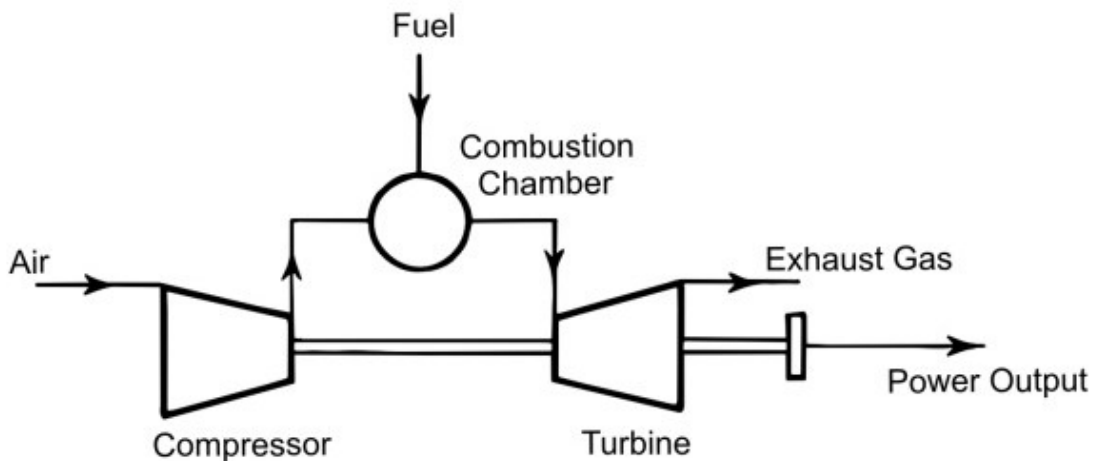

Figure 1. Simple gas turbine system

The gas turbine is a *steady flow* device in which air is compressed to a high pressure in the compressor, fuel is added in the combustion chamber, resulting in a high temperature at the turbine inlet; the hot gases are then expanded in the turbine back to atmospheric pressure. The expansion process provides significantly more power than is required by the compressor resulting in a net power which is available to the generator. The performance of the gas turbine will be dependent on the pressure ratio and turbine inlet temperature selected, with the former being limited by aerodynamic considerations and the latter by metallurgical, manufacturing and blade cooling considerations.

Note that in this *single shaft* configuration, the compressor and generator must run at the same rotational speed; it is also possible to use a gearbox to connect the compressor-turbine rotor to the generator. In practice it is found that large units will run at 3000 rpm for 50 Hz applications and 3600 rpm for 60 Hz applications. Compressors are designed on the basis of limiting tip speeds and inlet flow Mach numbers; it therefore follows that for constant tip speed the diameter of a machine designed for 3000 rpm will be 20 percent greater than for 3600 rpm machine.

The frontal area will be 44 per cent greater ( $1.2^2$ ) and hence the air flow will also be increased by 44 per cent. At present technology levels 50 Hz machines produce about 250 MW and 60 Hz machines about 175 MW. Units of 60 - 90 MW may be designed to run at higher speeds, with a reduction gearbox designed to give either 3000 or 3600 rpm generator speed, permitting them to be sold into both 50 and 60 Hz markets.

The single-shaft configuration is the norm for gas turbines designed for electric power generation.

When a jet engine is converted to provide a shaft power unit, the propelling nozzle is removed and a *power turbine* is fitted in its place. This configuration is shown in Figure. 2.

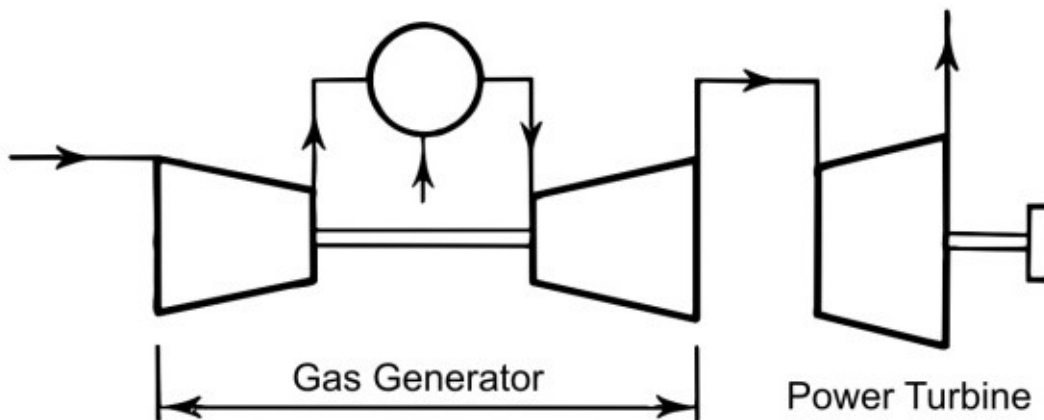

Figure 2. Gas turbine with separate power turbine

Note that in this case the compressor, combustor and turbine operate as a *gas generator* providing a stream of high pressure and high temperature gas which can then be expanded in the *power turbine* to provide electrical (or mechanical) output.

It is important to note that there is no mechanical connection between the gas generator and the power turbine and this *two shaft* arrangement is often described as a *free turbine* configuration.

For a chosen *design point*, with compressor pressure ratio and turbine inlet temperature specified, the thermodynamic performance of the single shaft and two shaft configurations is identical. The *part load* behavior, as power is reduced, is markedly different and the *off-design* performance will be briefly considered later.

### 3. Ideal Cycles

Analysis of ideal gas turbine cycles provides a clear understanding of the parameters affecting power output and thermal efficiency, and these idealized calculations can readily be extended to deal with real cycles. Analyses of ideal cycles can be found in texts on engineering thermodynamics [e.g. Rogers and Mayhew,1992] and only a brief resumé will be given here. The following assumptions are made:

- Compression and expansion processes are reversible and adiabatic (i.e. isentropic)
- The change of kinetic energy of the working fluid between inlet and outlet of each component is negligible.
- There are no pressure losses in the ducting or combustion chamber.
- The working fluid has the same composition throughout the cycle and is a perfect gas with constant specific heats; air will be assumed to be the fluid.
- The mass flow of gas is constant throughout the cycle.

#### 3.1 Simple Gas Turbine Cycle

The ideal cycle for the simple gas turbine is the Brayton cycle, i.e. cycle 1234 in Figure 3.

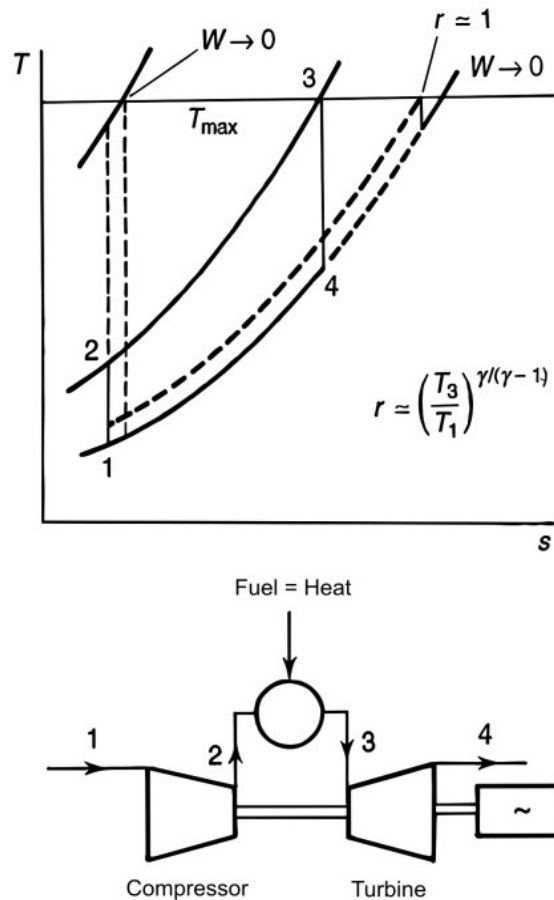

Figure 3. Simple cycle

The relevant steady flow equation is

$$Q = (h_2 - h_1) + \frac{1}{2}(C_2^2 - C_1^2) + W$$

where  $Q$  and  $W$  are the heat and work transfers per unit mass flow,  $h$  is the specific enthalpy and  $C$  the fluid velocity. Applying this to each component, we have

$$\text{Compressor work input} = h_2 - h_1 = c_p(T_2 - T_1)$$

$$\text{Combustor heat input} = h_3 - h_2 = c_p(T_3 - T_2)$$

$$\text{Turbine work output} = h_3 - h_4 = c_p(T_3 - T_4)$$

The cycle efficiency is

$$\eta = \frac{\text{net work output}}{\text{heat supplied}} = \frac{c_p(T_3 - T_4) - c_p(T_2 - T_1)}{c_p(T_3 - T_2)}$$

Making use of the isentropic  $p$ - $T$  relation, we have

$$T_2/T_1 = r^{(\gamma-1)/\gamma} = T_3/T_4$$

where  $r$  is the pressure ratio  $P_2/P_1 = P_3/P_4$ . The cycle efficiency is then readily shown to be given by

$$\eta = 1 - \left(\frac{1}{r}\right)^{(\gamma-1)/\gamma}$$

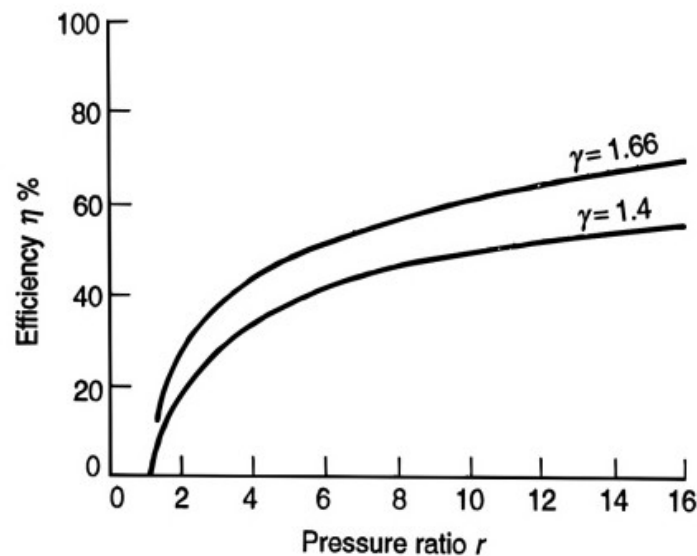

Figure 4. Efficiency for simple cycle

The efficiency thus depends only on the pressure ratio and the nature of the gas; Figure. 4 shows the result for  $\gamma = 1.40$ , the value normally assumed for air.

The specific work output  $W$ , upon which the size of the plant for a given power depends, is found to be a function of both pressure ratio and the maximum cycle temperature  $T_3$ . Thus

$$W = c_p (T_3 - T_4) - c_p (T_2 - T_1)$$

which can be expressed as

$$\frac{W}{c_p T_1} = t \left( 1 - \frac{1}{r^{(\gamma-1)/\gamma}} \right) - \left( r^{(\gamma-1)/\gamma} - 1 \right)$$

where  $t = T_3/T_1$ ;  $T_1$  is normally atmospheric temperature. It is therefore convenient to plot the specific work output in non-dimensional form ( $W/c_p T_1$ ) as a function of  $r$  and  $t$  as in Figure. 5. The value of  $T_3$ , and hence  $t$ , that can be used in practice is dependent on the maximum temperature which the highly stressed turbine blades can stand for the required working life; it is often called the 'metallurgical limit'. Early gas turbines used values of  $t$  around 4, but the use of air-cooled turbine blades allowed  $t$  to be increased to between 5 and 6.

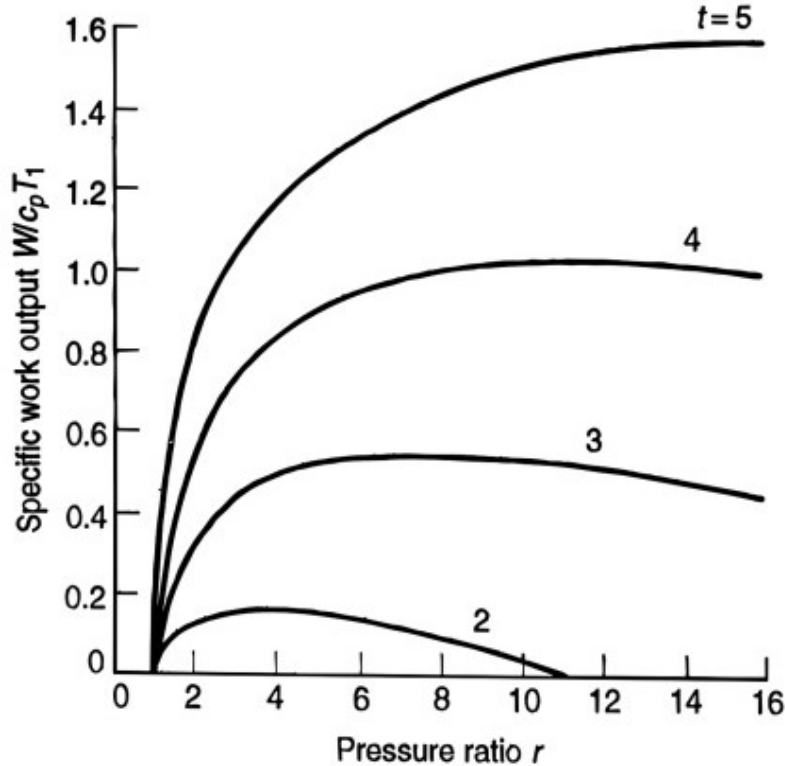

Figure 5. Specific work output for simple cycle

-  
-  
-

TO ACCESS ALL THE 23 PAGES OF THIS CHAPTER,  
Visit: <http://www.eolss.net/Eolss-sampleAllChapter.aspx>

### **Bibliography**

Rogers, G.F.C. and Mayhew, Y.R.; Engineering Thermodynamics, Work and Heat Transfer, 4th Edition, Longman 1992

Saravanamuttoo, H.I.H. , Rogers, G.F.C and Cohen,H. Gas Turbine Theory, 5 th Edn, Pearson Education, 2001

Lugand, P. and Parietti, C.; Combined cycle plants with Frame9F gas turbines, Transactions of the American Society of Mechanical Engineers Vol. 111, pp. 475-481, 1991.

### **Biographical Sketch**

**H.I.H.Saravanamuttoo** graduated from the University of Glasgow in 1955 and spent a decade working in the Canadian gas turbine industry on both aircraft and industrial engines. In 1964 he became a faculty member at the University of Bristol and worked as a consultant to Bristol Siddeley , Rolls Royce and British Aircraft Corporation on the Concorde engine development program, being awarded his PhD in 1968. From 1970-1998 he was at Carleton University , where he was Chairman of Mechanical and Aerospace Engineering for 10 years. During this period he was actively involved with gas turbine users on both sides of the Atlantic working on naval, aircraft, pipeline and utility applications. Since retirement in 1998 he has been Professor Emeritus at Carleton.

He is a Fellow of the American Society of Mech Engineers, the Institution of Mechanical Engineers and the Canadian Aeronautics and Space Institute and is a Past President of CASI. In 2002 he was the Guggenheim Memorial Lecturer, in 2004 recipient of the R.Tom Sawyer Award of ASME and in 2005 the MacCurdy Award of CASI.

He is co-author of " Gas Turbine Theory " now in its 5 th Edition and in continuous print since 1951.