

## STRUCTURE AND PROPERTIES OF POLYMERS

**Pavel Kratochvíl**

*Institute of Macromolecular Chemistry, Academy of Sciences of the Czech Republic, Prague, Czech Republic*

**Keywords:** Macromolecule, polymer, monomer, polymerization, statistical coil, material, polymer blend, copolymerization, modulus, glass transition, properties of polymers, rheology, viscoelasticity, additives, polymer processing, polymer characterization, drug delivery.

### Contents

1. Macromolecules and Polymers
  2. Synthesis of Polymers
  3. Structure of Macromolecules
  4. Structure of Polymers
  5. Design of Polymers with Specific Properties
  6. Mechanical Properties of Polymers
  7. Rheology and Viscoelasticity of Polymers
  8. Electric and Optical Properties of Polymers
  9. Additives
  10. Polymer Processing
  11. Polymers and the Environment
  12. Methods of Polymer Characterization
  13. Specialty Polymers
  14. Conclusion
- Acknowledgements  
Glossary  
Bibliography  
Biographical Sketch

### Summary

Polymers are modern materials produced in megaton quantities. The raw materials for their synthesis or biosynthesis are low-molecular-weight substances. In the synthesis, hundreds to many thousands of small monomer molecules undergo a polymerization reaction resulting in large molecules, termed macromolecules, mostly of chain-like structure. Polymers are substances consisting of macromolecules and the high molecular weight and chain-like structure of the macromolecules are responsible for the unique properties of polymers. The spectrum of applications of polymers is immense. For each application, the requirements for properties are specific and there are a number of ways to meet the requirements, such as mixing polymers with various types of additives, blending two or more polymers, combining polymers with particulate or fibrous materials, developing a new type of monomer, polymerizing two or more monomers together, or modifying chemically existing polymers. Mechanical properties of polymers can be varied over very broad ranges from hard to soft and from brittle to tough. To fabricate polymers into useful articles, the most frequently used techniques

are molding, blowing, calendaring, casting, extrusion, foaming, spinning of fibers, etc. Polymer waste is a serious burden for the environment because common organisms existing in nature are incapable of metabolizing them. Specialty polymers are materials having useful properties which cannot be found with any other material, produced in small quantities and applied in cases when the price is not too important. Main fields of application of those polymers are special electronics, space technology and medicine.

## 1. Macromolecules and Polymers

Macromolecules, i.e., big molecules, are molecules with large or very large molecular mass. Molecules of common low-molecular-weight substances, such as water -  $\text{H}_2\text{O}$ , oxygen -  $\text{O}_2$ , carbon dioxide -  $\text{CO}_2$ , toluene -  $\text{C}_6\text{H}_5\text{CH}_3$ , etc., have relative molecular masses of the order of magnitude of tens or hundreds. Macromolecules have masses hundred up to million times larger. High molecular mass and corresponding structural complexity of macromolecules are the causes of their specific properties.

For instance, a molecule of polyethylene, one of the most common synthetic plastics, a small section of which is described by the structure formula shown in Figure 1 comprises thousands up to hundreds of thousands of carbon atoms and its relative molecular mass can range from tens of thousands to millions.

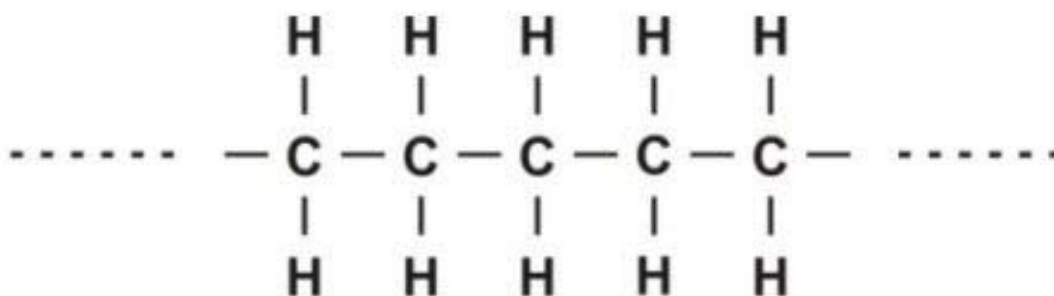

Figure 1. Formula of a small section of a molecule of polyethylene.

A polymer is a material which is composed of macromolecules of the same kind. Thus, polyethylene consists of a large number of polyethylene molecules. A material is classified as a polymer if an addition or subtraction of a few basic structural units to or from its macromolecules, i.e., in the case of polyethylene of a few  $-\text{CH}_2-$  units, does not change its properties perceptibly.

Substances composed of molecules containing a few up to tens of basic structural units, i.e.,  $-\text{CH}_2-$  groups in polyethylene, are called oligomers. Oligomers are a transition between low-molecular-weight substances and polymers. A change in the number of basic structural units in oligomer molecules results in an observable change of some properties of the substance.

According to their origin, polymers are divided into two basic groups, viz., natural polymers and synthetic polymers. The most important classes of natural polymers are polysaccharides - basic structural materials of plants, proteins - fundamental structural

materials of animals, and nucleic acids - carriers of genetic information. Synthetic polymers are modern materials surrounding us in everyday life as construction, insulation or packaging materials, synthetic fibers, coatings, etc.

The reactions by which all synthetic polymers and many natural polymers are formed from low-molecular-weight substances are controlled by laws of statistics and the resulting polymers comprise macromolecules with different molecular masses. The relative amount of molecules with specific values of molecular masses in a polymer is described by a distribution function of relative molecular mass. The distribution function affects significantly many properties of polymers and is one of their important characteristics.

## 2. Synthesis of Polymers

The mechanism of synthesis of natural polymers in living organisms, the biosynthesis, is extremely complex and is one of the most important topics in biochemistry. The chemistry of formation of macromolecules can more easily be described with synthetic polymers.

Low-molecular-weight substances used for synthesis of polymers are called monomers. Because of their specific structure and reactivity, monomers can undergo a reaction, called polymerization, which converts monomers to macromolecular substances, that is polymers. As examples, two basic and relatively simple types of polymerization reactions will be described, namely, radical polymerization and polycondensation.

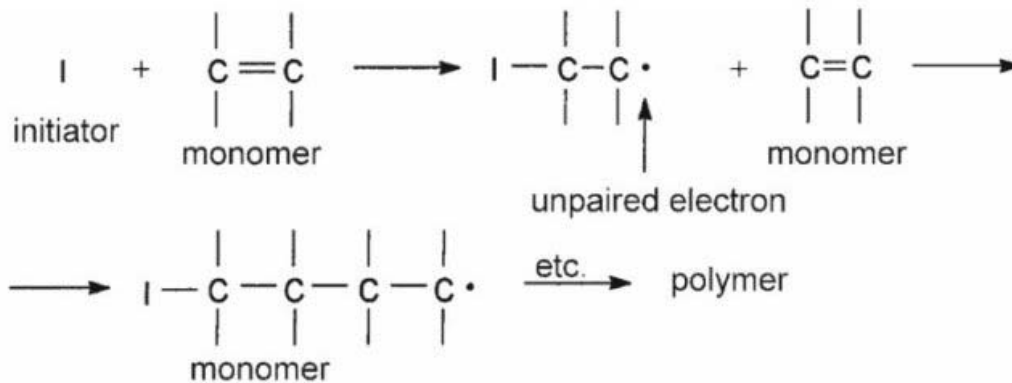

Figure 2. Scheme of radical polymerization.

The ability of monomers to polymerize radically is most frequently conditioned by the presence of a double bond between two adjacent carbon atoms in the molecule. Each of the two bonds is formed by two electrons shared by both carbon atoms. Through the action of substances called initiators, one of the bonds - figuratively speaking - disconnects in such a way that one of its electrons forms a bond with the initiator molecule and the second electron remains free, unpaired, for a short period of time. The structures with unpaired electrons are called free radicals, or just radicals, and hence the term radical polymerization. The radical resulting from the reaction of an initiator molecule with a monomer molecule has the potential to disconnect one of the two bonds

of the double bond of another monomer molecule and so to attach to the other molecule giving two joined monomer units with a free radical. This addition reaction repeats several hundred up to several thousand times and in this way a polymer molecule builds up.

The process of radical polymerization can be represented by the scheme shown in Figure 2.

As an illustration, the structures of three simple, but industrially extremely important monomers and polymers formed from them are given in Figures 3 and 4.

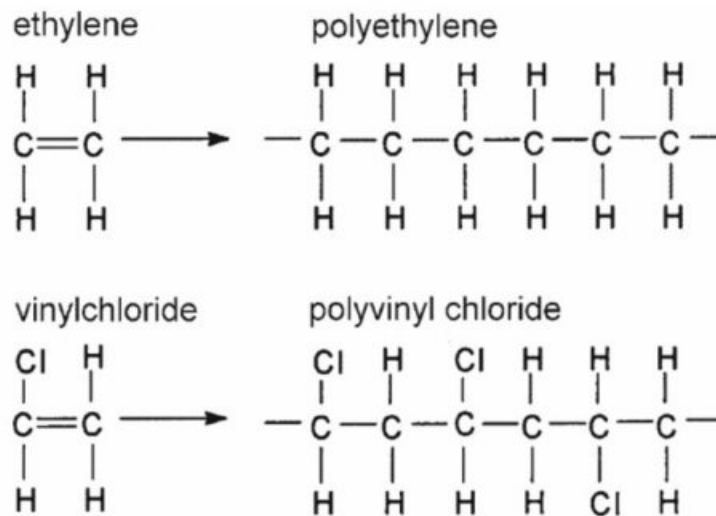

Figure 3. Structures of two important monomers and corresponding polymers

The name vinyl chloride derives from the combination of the name of vinyl group ( $-\text{CH}=\text{CH}_2$ ) and the name of salts with chloride anions, i.e., chloride. The name is not quite rigorous, because the bond between vinyl and chlorine is a covalent, not ionic bond, which means that vinyl chloride is not a salt. A molecule of styrene consists of vinyl group  $-\text{CH}=\text{CH}_2$  and a benzene ring  $-\text{C}_6\text{H}_5$ . Thus, an alternative name of styrene could be vinylbenzene (Figure 4).

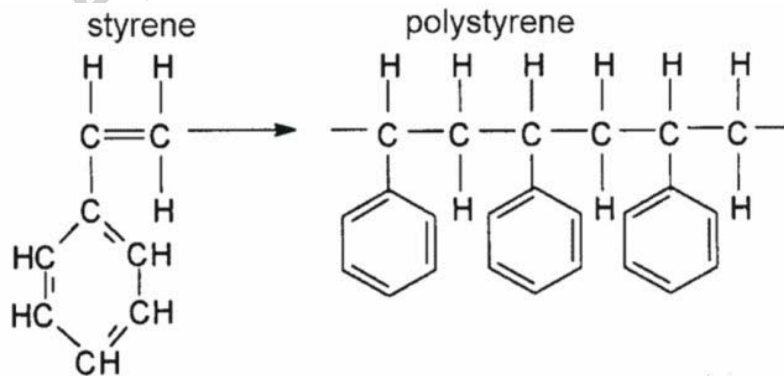

Figure 4. Structure of styrene and polystyrene.

As far as the volume of production is concerned, the above three polymers are basic products of the huge industry of synthetic polymers, the world production of which amounts to tens of millions of metric tons.

Condensation in organic chemistry means reactions in which two molecules join giving rise to a larger molecule while a small molecule, often a molecule of water, is eliminated. For instance, a carboxylic acid, the characteristic group of which is  $-\text{COOH}$ , reacts with an alcohol, the characteristic group of alcohols being  $-\text{OH}$ , with the elimination of molecule of water to form a molecule of ester (Figure 5).

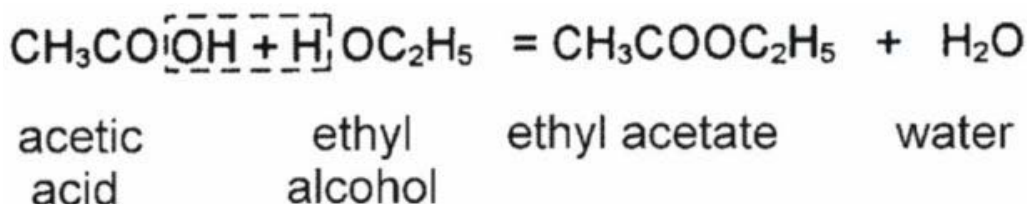

Figure 5. Condensation of acetic acid with ethyl alcohol.

To utilize the principle of condensation for synthesis of macromolecules, we must start with a monomer, or more than one type of monomers the molecules of which have two or more functional groups capable of condensation. Thus, for example, suitable monomers for polycondensation are hydroxy acids, with the general formula  $\text{HORCOOH}$ , each molecule of which contains both one carboxylic-acid and one hydroxy group. By a multiplicity of condensation steps, i.e., by a polycondensation reaction, a polyester macromolecule forms (Figure 6).



Figure 6. Formula of a section of a polyester molecule formed by polycondensation of a hydroxy acid.

An alternative way to synthesize polyesters is to start from two monomers, viz., a dicarboxylic acid, general formula  $\text{HOOCR}_1\text{COOH}$ , and a dialcohol, i.e., diol, general formula  $\text{HOR}_2\text{OH}$ . The reaction of these two monomers yields a polyester with a somewhat different structure (Figure 7).



Figure 7. Formula of a section of a polyester molecule formed by polycondensation of a dicarboxylic acid and a dialcohol

In addition to radical polymerization and polycondensation, there exist a large number of other important mechanisms of polymerization. Also the number of monomers and corresponding polymers is extremely large, in fact unlimited. Out of the vast amount of polymers described in the literature, only a minute fraction are produced industrially.

If more than one monomer is used in a polymerization reaction, the process is called copolymerization and the resulting polymer is a copolymer. Using various combinations of monomers and varying their ratios in the copolymerization, a literally infinite number of copolymers can be prepared. The sequential distribution of the monomeric units in the copolymer molecules plays the major role in determining the properties of the copolymer. The most important types of copolymers are statistical copolymers and block copolymers. In a binary statistical copolymer of monomers A and B, the sequential order of monomeric units is controlled by some type of statistics and the structure of a segment of a copolymer molecule can be represented schematically as ...AAABABBBBAABBABB... In a block copolymer, identical monomeric units form long sequences, thus A..AAA..AB..BB..BA..AAA..A would be a schematic representation of a triblock copolymer.

### 3. Structure of Macromolecules

By the reactions described in Section 2, essentially linear, chain-like macromolecules are formed. Parts of a molecule adjacent to a single bond rotate about this bond. In a typical macromolecule, there are a large number of single, mostly C–C bonds. An isolated macromolecule, e.g., in highly dilute solution, assumes - due to the fast rotation of its parts about all single bonds - in time a large, virtually infinite number of conformations from densely coiled to extended ones. By far the most frequent conformations are those called statistical or random coil (Figure 8). In the domain occupied by a macromolecule with random-coil conformation, the segments of the macromolecule occupy just a small volume fraction of the volume of the domain, typically a few per cent or even less, most of the space being occupied by solvent molecules or segments of other macromolecules. The concept of statistical coil is of prime importance for the understanding of the relations between structure and properties of polymers.



Figure 8. Sketch of a statistical coil conformation of a macromolecule.

If some or all monomer molecules in a polymerizing system have two double bonds, or more than two groups capable of undergoing a polycondensation reaction, the resulting macromolecules are not linear but branched (Figure 9). For instance, when a monomer molecule with three functional groups capable of condensation is incorporated in a macromolecule, it can become a trifunctional branch point because three chains can emanate from it. Similarly, a monomer molecule containing two double bonds or four functional groups capable of condensation can give rise to a tetrafunctional branch point in a forming macromolecule because four chains can meet at this point. Branch points can also be generated in existing macromolecules by irradiation, heat treatment, aging and some other processes. There are several types of reactions that result in branched macromolecules with trifunctional branch points in which the macromolecular side chains are attached to the main chain, the backbone; macromolecules of this type are called graft macromolecules.



Figure 9. Sketches of branched macromolecules. a) Trifunctional branch points; b) tetrafunctional branch points; c) graft macromolecule

TO ACCESS ALL THE 22 PAGES OF THIS CHAPTER,  
Visit: <http://www.eolss.net/Eolss-sampleAllChapter.aspx>

### Bibliography

Alger M.S. (1989) *Polymer Science Dictionary*, 532 pp. Elsevier Science Publishers. [The book comprises definitions and explanations of terms from polymer chemistry and physics.]

Billmeyer F.W., Jr. (1984). *Textbook of Polymer Science*, 3rd Ed., 578 pp. John Wiley and Sons. [Classical introduction to polymer science.]

Comprehensive Polymer Science (eds G. Allen and J.C. Bevington), in 7 Volumes, Pergamon Press 1989; 1st Supplement 1992; 2nd Supplement 1996. [Fundamental source of knowledge in polymer science covering synthesis, structure, and properties of polymers.]

Elias H.-G. (1987). *Mega Molecules*, 202 pp. Springer Verlag. [The book provides a well readable access to the world of giant molecules.]

Elias H.-G. (1990) *Makromoleküle, Band 1, Grundlagen*, 1037 pp. Hüthig and Wepf Verlag. [Covers structure, synthesis, and properties of polymers; highly valued textbook.]

Elias H.-G. (1992). *Makromoleküle, Band 2, Technologie*, 792 pp. Hüthig and Wepf Verlag. [Covers raw materials, industrial syntheses of polymers, material properties and applications of polymers; highly valued textbook.]

Encyclopaedia of Polymer Science and Engineering (eds H.F. Mark, N.M. Bikales, C.G. Overberger, and G. Menges), in 17 Volumes, John Wiley and Sons, 1985-1989; Supplement Volume 1989; Index Volume 1990. [Fundamental work covering the whole of polymer science and engineering.]

Munk P. (1989). *Introduction to Macromolecular Science*, 522 pp. John Wiley and Sons. [Textbook covering the whole of polymer science.]

### **Biographical Sketch**

**Pavel Kratochvíl** was born in Prague, Czech Republic, in 1930. He graduated in chemical engineering at the Institute of Chemical Technology in Prague and received his PhD and DSc degrees in macromolecular chemistry from the then Czechoslovak Academy of Sciences in 1960 and 1968, respectively. For most of his professional career, he has been affiliated as a Chief Research Fellow with the Institute of Macromolecular Chemistry of the Academy of Sciences of the Czech Republic in Prague, one of the major institutes devoted to basic research in polymer science world-wide. From 1990 to 1998, he served two four-years terms as the director of the Institute. He is also professor of macromolecular chemistry at the Institute of Chemical Technology in Prague.

Prof. Kratochvíl's main field of activity is the physical chemistry of polymers, particularly the characterization and determination of molecular parameters of polymers and copolymers, and light scattering from polymer solutions. He is the author or co-author of more than 190 original communications in international journals, ten reviews, one monograph and five contributions to monographs. He has presented about 250 invited lectures and communications at international meetings and lectures at foreign universities and research institutions.

Prof. Kratochvíl is a Founding Member of the Learned Society of the Czech Republic, Fellow of the Royal Society of Chemistry, UK, member of numerous boards, both national and international, and member of five editorial boards of international technical journals. He is a holder of several respected awards. He has spent his sabbatical leaves as a visiting scientist or visiting professor in Canada, Germany, India, Japan, Mexico, Russia, Sweden, and the United States.